

PALIFT SPIDER AERIAL PLATFORMS



Palazzani
INDUSTRIE

Palazzani is a company with over 80 years of history, specialised in the designing and development of Earth Moving Machines and Aerial Platforms. A fierce Italian Company, able to stand its position in a everchanging scenario and to expand its business in an increasingly global and competitive market.

Our customers are skilled people who recognise and expect quality, especially when it comes as the result of choices mixing technology and passion. They continue to demand the highest quality, which meets or exceeds their expectations, and are able to communicate directly with the people at Palazzani who continue to create, innovate and produce the exceptional machines.

Davide Palazzani, C.E.O.

1935

the Palazzani Company was born in 1935, from a small workshop, which began manufacturing agriculture equipment



1950

first Earth Moving Machines were produced, a range of hydraulically operated 4WD Wheeled Loaders, excavators and cranes

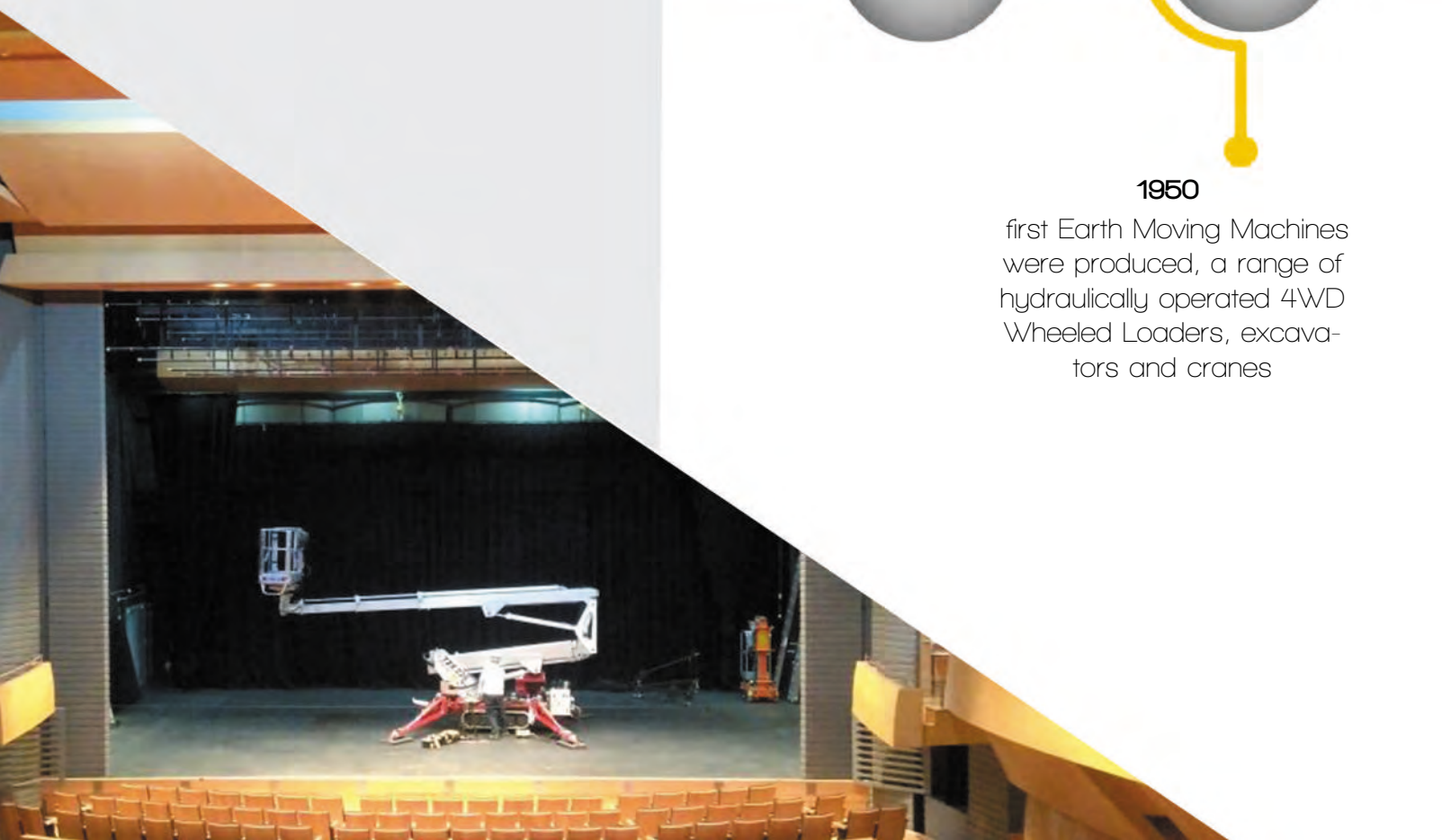



1980

the positive feedback from the market allowed the Company to enlarge and progressively differentiate its manufacturing field and to become a joint-stock Company



1990

the first platform Ragno is launched and the production range is divided in Palift and Paload Divisions

YOUR SATISFACTION IS OUR SUCCESS

To achieve the double objective personalization + profitability, Palazzani applies innovative and unique technological solutions regarding ergonomics, performances, environmental responsibility and safety to its machines. Every Palazzani machine is developed and built to satisfy its user

OUR RANGE OF SPIDER AERIAL PLATFORMS

TZX SERIES

TZX 170



TSJ SERIES

TSJ 23.1

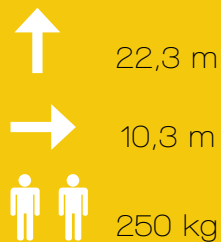

TSJ 25

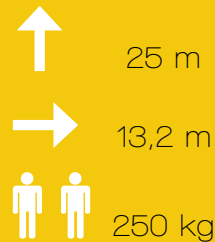

TSJ 27

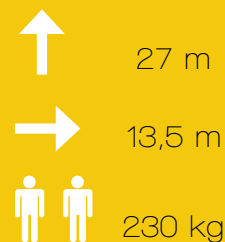

TSJ 30.1

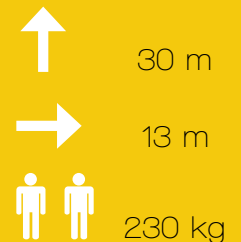

XTJ SERIES

XTJ 32

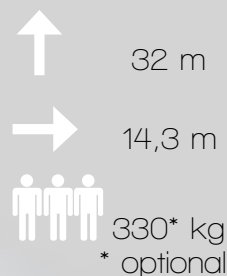

XTJ 37⁺

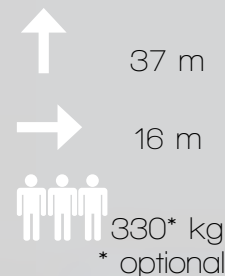

XTJ 43⁺



TZ SERIES

TZ 330⁺

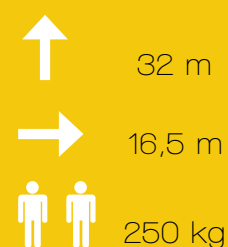

FORMS - PALIFT

TZX 190

↑ 19 m

→ 8,5 m

👤 👤 200 kg

TZX 225

↑ 22,5 m

→ 10,25 m

👤 👤 200 kg

TSJ 35

↑ 35 m

→ 15 m

👤 👤 230 kg

TSJ 39

↑ 39 m

→ 16,5 m

👤 👤 230 kg

XTJ 48.1⁺

↑ 49 m

→ 19,3 m

👤 👤 👤 330* kg
* optional

XTJ 52⁺

↑ 52 m

→ 19,5 m

👤 👤 👤 👤 400* kg
* optional

All our products are Certified:



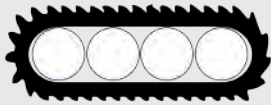

CRAWLER VERSION

Suitable for driving on:

- all terrains
- rough terrains
- steep slopes
- delicate and low capacity floors

(the weight is well distributed over the tracks surface)

- indoor flooring with the optional non-marking tracks





WHEEL VERSION

Suitable for driving on:

- flat floors
- delicate floors, thanks to the super-elastic rubber and non-marking wheels
- indoor flooring, for easy maneuverability and steering

POWER OPTIONS FOR EVERY NEED

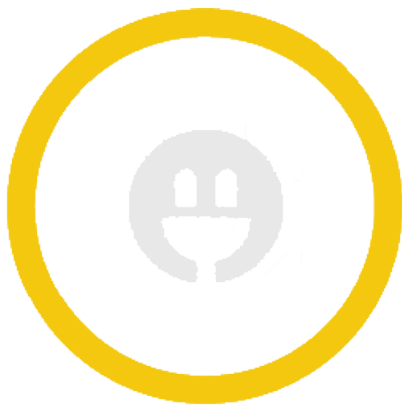

ECO

Electric Motor + Batteries
(lead-acid - lithium - gel)

Completely ecological and with zero emissions, to be used in indoor environments and where the use of the diesel engine is not permitted.

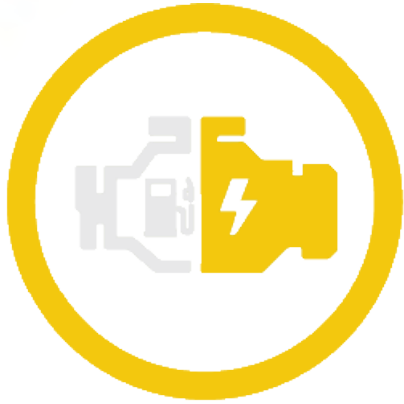

BI-ENERGY (STANDARD VERSION)

Diesel Engine + Electric Motor

Thanks to the dual-motor operation in this version, the platform can be used both outdoor, with the diesel engine, and inside buildings with zero emissions, thanks to the single-phase electric motor, powered by domestic electricity.

HYBRID

Diesel Engine + Batteries
(lead-acid - lithium - gel)

Ideal to be used both in outdoor environments (diesel engine) and in indoor where there is no access to electricity and the use of the diesel engine is not permitted.

TZX SERIES BENEFITS

↑ 17 m

TZX 170 → 7,8 m

↑ ↓ 200 kg

↑ 19 m

TZX 190 → 8,5 m

↑ ↓ 200 kg

↑ 22,5 m

TZX 225 → 10,25 m

↑ ↓ 200 kg

Cage 140x70x110 cm: easy to remove and complete of 230 V socket

Basket made of aluminum with a minimum capacity of 120 kg and a maximum of 200 kg, with standard dimensions of 140x70x110 cm fastened to the arm by quick coupling, easily dismantled when needed for narrow passages.

Fixed control panel on the basket for all aerial manoeuvres.

230V electrical outlet in the basket to use tools during the aerial work

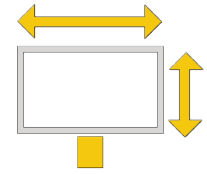

Agility and compactness

The excellent weight / performance ratio, and the small size, make these platform Spiders ideal for aerial working in places inaccessible to other types of MEWP. The ability to drive on any type of terrain, automatic chassis leveling and set-up even on slopes make them even more versatile and suitable for use in hostile places

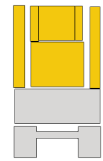

Manual stabilizers set-up

Stabilizers can be set-up anywhere thanks to the manual mode. Really useful when working in areas where precise or individual control is needed

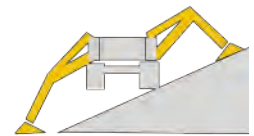

Easy maintenance and use

The platform is equipped of monitoring systems to simplify preventive maintenance.



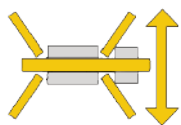

2 set-up positions

Two distinct set-up positions: wide and narrow, to adapt the machine to suit different site requirements (available on TZX225).

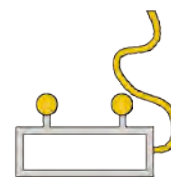

Wire control

Cable control connected to the main panel, to perform all the maneuvers of the platform from the ground.

TZX SERIES OPTIONAL ITEMS

Radio control

Remote control, by radio-wave, for long distance control and maneuvering. Available with unique (interchangeable) control panel, or double control panels (in the cage and on the turntable).



Automatic self-levelling system

Electronic Stabilizer Self-Leveling System for TZX Series. In addition to the manual system, available on the TZX series machines, the automatic option is available, allowing the leveling of the chassis automatically even on important slopes (15-25%, depending on the model), allowing Spider placement on roads and irregular grounds, or stairs.



Electric wire winch 200kg

Easily interchangeable with the cage; powered directly from the on-board generator.



2nd transfer speed kit

2nd speed for TZX. Increased speed up to 2.4 km / h to use with Spider in transfer position.



Anti-collision kit for basket

Operator protection system on the platform. Laser sensors are placed at the four corners of the basket, to prevent the basket approaching to obstacles at 3 m distance. Ultrasonic sensors are placed under the basket to prevent the collision of the cage with obstacles located nearby.

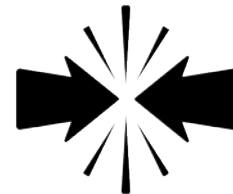

"Back to home" function

The "back to home" function allows to automatically retract the arm into the transport position.





Intercom

Phone device for voice communication between basket and ground.

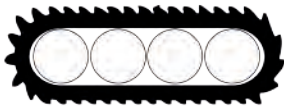

Non-marking tracks

To operate on delicate floor.

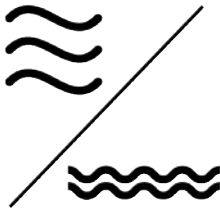

Additional hoses air/water

Additional hoses for compressed air/water.

Additional hoses (large size) for high pressure and temperature water.



Anemometre

With acoustic warning of wind max speed.



Additional stabilizer pads

Additional plates to distribute the stabilizer load on the ground and to have greater stability of the machine. Available in:

lightweight, exceptionally strong engineered thermoplastic material

thermoplastic material with adapting guides

galvanized steel with handles and adapting guides.



Additional protections

Stabilization protection:

Steel guard for stabilizer cylinders to cover a delicate part of the machine that could be damaged by falling materials.

Tree cutters protection:

Steel guard kit for delicate machine equipment such as cylinders, valves and winding drums in case of material falling from above, such as branches.

TSJ SERIES BENEFITS



22,3 m

TSJ 23.1



10,3 m



250 kg



25 m

TSJ 25



13,2 m



250 kg



27 m

TSJ 27



13,5 m



230 kg



30 m

TSJ 30.1



13 m



230 kg



35 m

TSJ 35



15 m



230 kg



39 m

TSJ 39



16,5 m



230 kg

Basket 180x70x110 cm: big, easy to remove and complete of 230 V socket

Basket made of aluminium with a minimum capacity of 120 kg and a maximum of 230 kg, with standard dimensions of 180x70x110 cm that leaves plenty of room for the operator. Fastened to the arm by quick coupling, easily dismantled.

Fixed control panel on the basket for all aerial maneuvers. 230V electrical outlet in the basket to use tools during the aerial work. (On TSJ 23.1 model the basket is 150x70x10 cm, on TSJ 39 the basket is 240x70x110 mm)

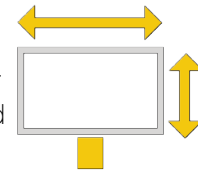

Telescopic boom and jib in super resistance steel with additional air/water hoses inside

The multi-telescopic arm and the articulated upper jib offer maximum aerial agility, with zero tailswing, even at medium height. The booms are constructed of high strength steel - STRENGTH. The arm rotation is 660° with any placement. Pipes and cables are safely routed inside the boom for protection from damage, and all of the machines are equipped with pipes for both air and water in the basket.



Easy and safe during aerial work

The platform is equipped with intelligent outreach system, which automatically controls the outreach. The working area automatically adapts to the position of the stabilisers and the load in the basket, ensuring maximum performance and safety.

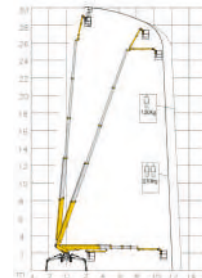

Agility and Compactness

The excellent weight / performance ratio and the small size, make this platform Palazzani Spider ideal for aerial working in places inaccessible to other types of MEWP. The ability to drive on any type of terrain, automatic chassis leveling and set-up even on slopes makes it even more versatile and suitable for use in hostile places.

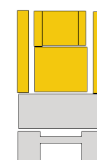

Intercom

Communication between basket and ground operators during the aerial work, thanks to an intercom system installed both in the basket and in the lower part of the machine (standard on TSJ 35 and TSJ 39, optional in the other models).

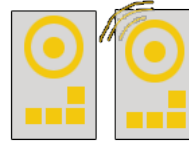

Wireless maneuverability

The standard radio-control allows to maneuver the platform from the ground with agility and without needing a cable.

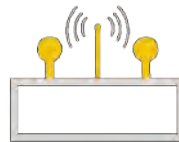

Adjustable and easy drive

Crawler chassis with adjustable width: narrow crawlers allow a reduced width suited for maneuvering in narrow spaces and delicate floors, while large rubber tracks are suited for driving safely on slopes and rough terrain.

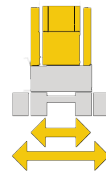

Easy maintenance and use

Thanks to the use of a touch-screen monitor, the user can access to detailed information about the machine and to very advanced diagnostic functions.



Independent stabilizers with automatic set-up

Each stabilizer can be independently rotated, in 2 different positions, for setting up in narrow spaces, with automatic and manual set-up.

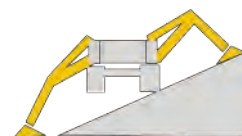

TSJ SERIES OPTIONAL ITEMS

Electric winch 200kg

Easily interchangeable with the cage; powered directly from the on-board generator.

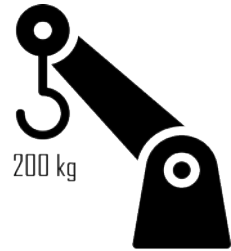

Hydraulic winch 500kg

The winch, in place of the cage, transforms the Spider Lifts in Spider Crane, with 500 kg of max lifting capacity. Controlled by the same controls as the Spider Lift. The working diagram automatically fits without any intervention from the operator

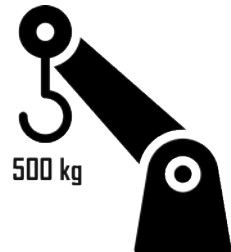

Radio control

(standard for TSJ 35/39 models)

Remote control, by radio-wave, for long distance control and maneuvering. Available with unique (interchangeable) control panel, or double control panels (in the cage and on the turntable).



Electric generator

230VAC single-phase, powered by the diesel engine, connected to the socket in the cage.



Non marking tracks

To operate on delicate floor.

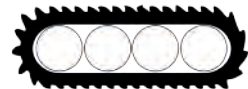

Double speed kit for TSJ

Increase of travel speed for TSJ Series.
Increase of 50/60% for models TSJ 23.1/25/27/30.1.
Increase of 30/40% for models TSJ 35/39.
To use with Spider in transfer position.



Additional hoses air/water

Additional hoses for compressed air/water.
Additional hoses (large size) for high pressure and temperature water.

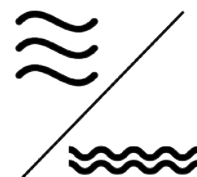



Monitor in the basket

Latest generation touch screen colour monitor which provides detailed information of the machine during aerial work. Available with multi-language options



PalConnect Kit

The PalConnect Kit is a "ready to go" kit that can be integrated into the Spider Platform, allowing the customer to own a "Industry 4.0 compliant" product. It offers a remote connection service with the Aerial Platform and allows the operator to record and control some main parameters of the machine.



Anemometre

With acoustic warning of wind max speed.

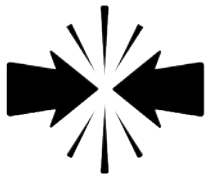

Anti-collision kit for basket

Operator protection system.

Laser sensors are placed at the four corners of the basket and activate at 3m distance, to prevent from trapping incidents.

Ultrasonic sensors are placed on the basket to prevent the collision of the cage with obstacles located nearby.



Intercom

Phone device for voice communication between basket and ground.



Cages in different sizes

One-man aluminum basket size 70x70x110 cm, particularly suitable for work in tight spaces.

240x70x110cm aluminium cage for lifting more operators or materials.



Additional stabilizer plates

Additional plates to distribute the stabilizer load on the ground and to have greater stability of the machine. Available in:

lightweight, exceptionally strong engineered thermoplastic material

thermoplastic material with adapting guides.

galvanized steel with handles and adapting guides.



Additional protections

Stabilization protection: steel guard for stabilizer cylinders to cover a delicate part of the machine that could be damaged by falling materials.

Tree cutters protection: steel guard kit for delicate machine equipment such as cylinders, valves and winding drums in case of material falling from above, such as branches.

PLUS⁺

+ FASTER

Important operating efficiency thanks to the introduction of the CAN-bus. This innovative system increases the speed of the machine during aerial work.

+ MORE PRECISE

High precision of aerial movements to carry out at best every delicate operation, in total safety.

+ MORE EFFICIENT

Important energy and working time savings, thanks to extremely smooth movements.



SERIES



+ INTERCONNECTED

Through the PalConnect Kit, the operator can interconnect the platform to other softwares, control and monitor the main functions of the Spider Lift from remote.

+ COMFORTABLE

Thanks to the "return to home" function, the machine switches automatically from working to transport position.

+ SAFER

The Easy Drive option simplifies truck loading operations. Innovative transfer system for same crawler speed, to avoid unintentional steering.

XTJ SERIES BENEFITS

XTJ 32

↑ 32 m

→ 14,3 m

330* kg
* optional

XTJ 37+

↑ 37 m

→ 16 m

330* kg
* optional

XTJ 43+

↑ 43 m

→ 18 m

330* kg
* optional

XTJ 48.1+

↑ 49 m

→ 19,3 m

330* kg
* optional

XTJ 52+

↑ 52 m

→ 19,5 m

400* kg
* optional

Basket 240x70x110 cm: big, easy to remove and complete of 230 V socket

Basket made of aluminium with a minimum capacity of 120 kg and a maximum of 230 kg (*330/400 kg optional), with standard dimensions of 240x70x110 cm. It is fastened to the arm by quick coupling, easily dismantle. Fixed control panel on the basket for all aerial maneuvers. 230V electrical outlet in the basket to use tools during the aerial work. (standard for XTJ 43/XTJ 48.1 e XTJ 52 - for XTJ 32/XTJ 37 the standard basket is 180x70x110 cm)

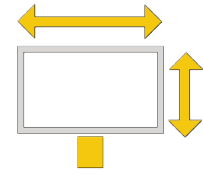

Telescopic boom and jib in super resistant steel with additional air/water hoses inside

The multi-telescopic arm and the articulated upper jib offer maximum aerial agility, with zero tailswing, even at medium height. The booms are constructed of high strength steel - STRENGTH. The arm rotation is 660° with any placement. Pipes and cables are safely routed inside the boom for protection from damage, and all of the machines are equipped with air/water hoses for the use of the basket equipment.



Easy and safe during aerial work

The platform is equipped with intelligent outreach system, which automatically controls the outreach. The working area automatically adapts to the position of the stabilisers and the load in the basket.

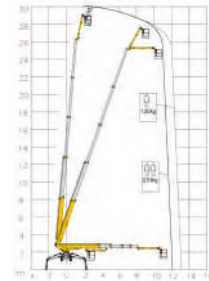

Agility and compactness

The excellent weight / performance ratio and the small size, make this platform Palazzani Spider ideal for aerial working in places inaccessible to other types of MEWP. The ability to drive on any type of terrain, automatic chassis leveling and set-up even on slopes makes it even more versatile and suitable for use in hostile places.



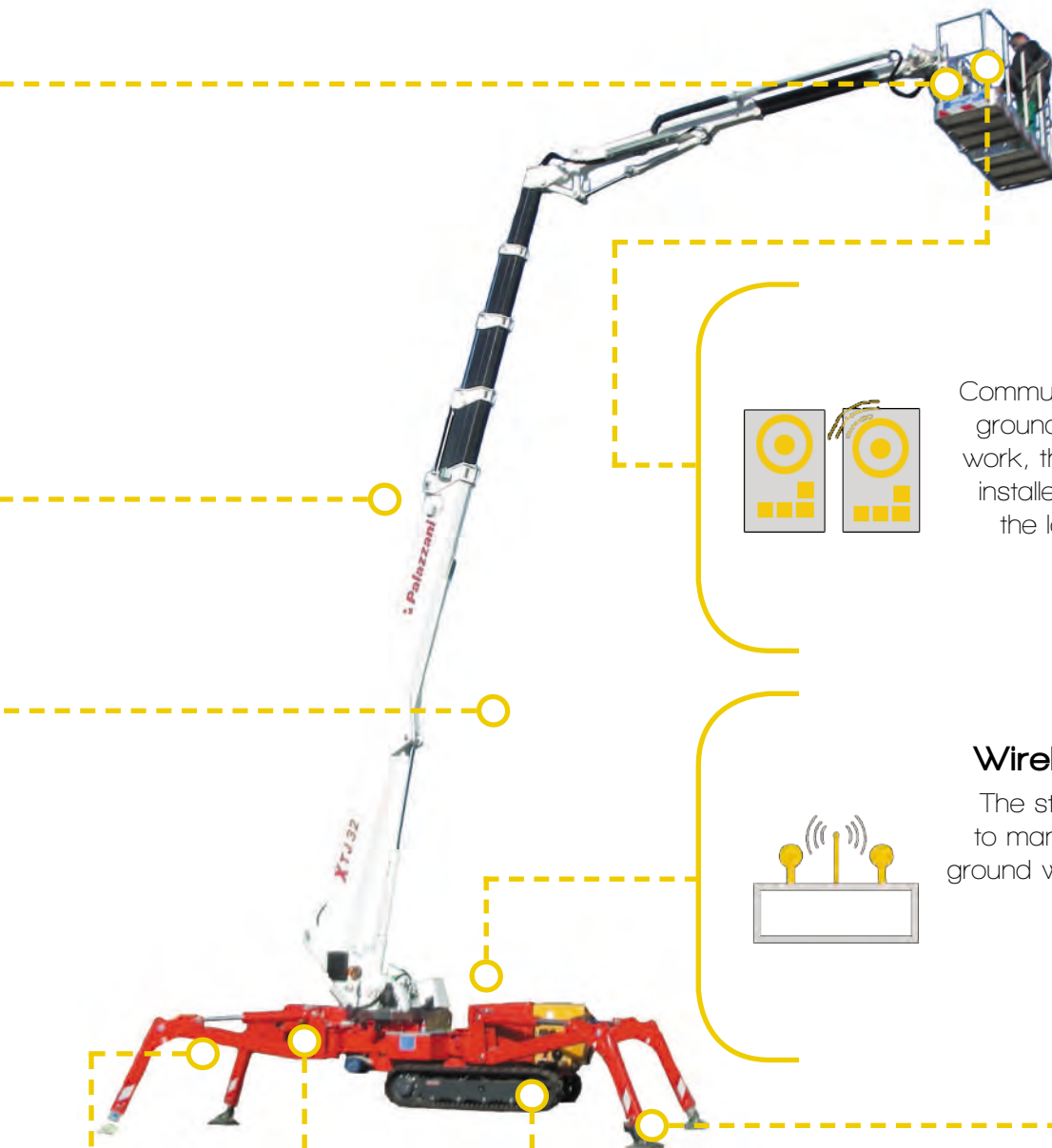

Intercom

Communication between basket and ground operators during the aerial work, thanks to an intercom system installed both in the basket and in the lower part of the machine.

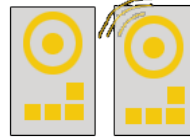

Wireless maneuverability

The standard radio-control allows to maneuver the platform from the ground with agility and without needing a cable.

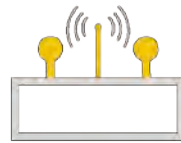

Easy maintenance and use

Thanks to the use of a touch-screen monitor, the user can access to detailed information about the machine and to very advanced diagnostic functions.

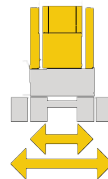

Adjustable and easy drive

Crawler chassis with adjustable width: narrow crawlers allow a reduced width suited for maneuvering in narrow spaces and delicate floors, while large rubber tracks are suited for driving safely on slopes and rough terrain.



Independent stabilizers with automatic set-up

Each stabilizer can be independently rotated, in 2 different positions, for setting up in narrow spaces, with automatic and manual set-up.

XTJ SERIES OPTIONAL ITEMS

3rd Working area

Work area with increased load to work with 330kg in the basket
400kg only on XTJ 52.

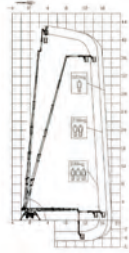

Hydraulic winch 500kg

The winch, in place of the cage, transforms the Spider Lifts in Spider Crane,
with 500 kg of max lifting capacity.
Controlled by the same controls as the Spider Lift.
The working diagram automatically fits without any intervention
from the operator.



Electric winch 200kg

Easily interchangeable with the cage; powered directly from the on-board
generator.



Electric generator

230VAC single-phase, powered by the diesel engine, connected to the
socket in the cage.



Non-marking tracks

To operate on delicate floor.

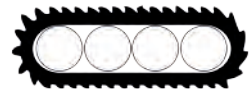

PalConnect Kit

The PalConnect Kit is a "ready to go" kit that can be integrated into the
Spider Platform, allowing the customer to own a "Industry 4.0 compliant"
product. It offers a remote connection service with the Aerial Platform and
allows the operator to record and control some main parameters
of the machine.



Anemometre

With acoustic warning of wind max speed.





Monitor in the basket

Latest generation touch screen colour monitor which provides detailed information of the machine during aerial work. Available with multi-language options.

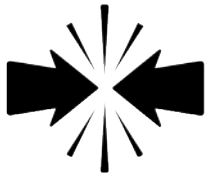

Anti-collision kit for basket

Operator protection system.

Laser sensors are placed at the four corners of the basket and activate at 3m distance, to prevent from trapping incidents.

Ultrasonic sensors are placed on the basket to prevent the collision of the cage with obstacles located nearby.



Additional hoses air/water

(Standard for XTJ 37/43/48.1/52)

Additional hoses for compressed air/water.

Additional hoses (large size) for high pressure and temperature water.



Intercom

(Standard for XTJ 37/43/48.1/52)

Phone device for voice communication between basket and ground.



Cages in different sizes

One-man aluminum basket size 70x70x110 cm, particularly suitable for work in tight spaces.

240x70x110cm aluminium cage for lifting more operators or materials.



Additional stabilizer pads

Additional plates to distribute the stabilizer load on the ground and to have greater stability of the machine. Available in:

lightweight, exceptionally strong engineered thermoplastic material

thermoplastic material with adapting guides.

galvanized steel with handles and adapting guides.



Additional protections

Stabilization protection: steel guard for stabilizer cylinders to cover a delicate part of the machine that could be damaged by falling materials.

Tree cutters protection: steel guard kit for delicate machine equipment such as cylinders, valves and winding drums in case of material falling from above, such as branches.

TZ SERIES BENEFITS



32 m

TZ 330+



16,5 m



250 kg

Innovative pantograph boom

The boom is made of high strength steel and designed with an innovative shape combining reduced weight with exceptional strength.

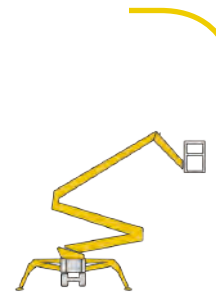

Intercom

Communication between basket and ground operators during the aerial work, thanks to an intercom system installed both in the basket and in the lower part of the machine

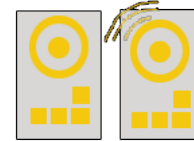

High energy saving

Hydraulic system with pump at variable displacement and distributor with can-bus technology for important energy savings, compared to traditional systems.

The new system combines high levels of safety with smooth and precise control.



Agility and compactness

The excellent weight / performance ratio and the small size, make this Spider Lift ideal for aerial working in places inaccessible to other types of MEWP. The ability to drive on any type of terrain, automatic chassis leveling and set-up even on slopes makes it even more versatile and suitable for use in hostile places.

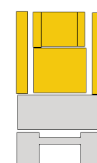

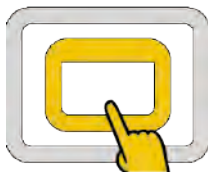

Easy maintenance and use

Thanks to the use of a touch-screen monitor, the user can access to detailed information about the machine and to very advanced diagnostic functions.

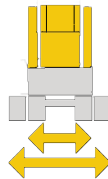

Adjustable and easy drive

Crawler chassis with adjustable width: narrow crawlers allow a reduced width suited for maneuvering in narrow spaces and delicate floors, while large rubber tracks are suited for driving safely on slopes and rough terrain.

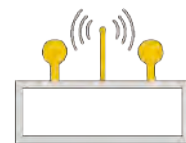

Wireless maneuverability

The standard radio-control allows to maneuver the platform from the ground with agility and without needing a cable.

TZ SERIES OPTIONAL ITEMS

Electric winch 200kg

Easily interchangeable with the cage; powered directly from the on-board generator.



Non marking tracks

To operate on delicate floor.

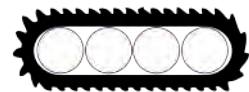

Additional hoses air/water

Additional hoses for compressed air/water.
Additional hoses (large size) for high pressure and temperature water.

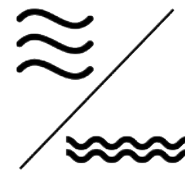

Electric generator

230VAC single-phase, powered by the diesel engine, connected to the socket in the cage.



PalConnect Kit

The PalConnect Kit is a "ready to go" kit that can be integrated into the Spider Platform, allowing the customer to own a "Industry 4.0 compliant" product. It offers a remote connection service with the Aerial Platform and allows the operator to record and control some main parameters of the machine.



Intercom

Phone device for voice communication between basket and ground.





Monitor in the basket

Latest generation touch screen colour monitor which provides detailed information of the machine during aerial work. Available with multi-language options.

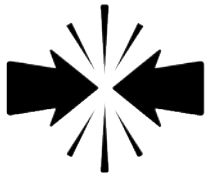

Anti-collision kit for basket

Operator protection system.

Laser sensors are placed at the four corners of the basket and activate at 3m distance, to prevent from trapping incidents.

Ultrasonic sensors are placed on the basket to prevent the collision of the cage with obstacles located nearby.



Anemometre

With acoustic warning of wind max speed.



Cages in different sizes

One-man aluminum basket size 70x70x110 cm, particularly suitable for work in tight spaces.

240x70x110cm aluminium cage for lifting more operators or materials.



Additional stabilizer pads

Additional plates to distribute the stabilizer load on the ground and to have greater stability of the machine. Available in:

lightweight, exceptionally strong engineered thermoplastic material

thermoplastic material with adapting guides.

galvanized steel with handles and adapting guides.



Additional protections

Stabilization protection: steel guard for stabilizer cylinders to cover a delicate part of the machine that could be damaged by falling materials.

Tree cutters protection: steel guard kit for delicate machine equipment such as cylinders, valves and winding drums in case of material falling from above, such as branches.

 **Palazzani**
INDUSTRIE



Palazzani Industrie S.p.A.

Via del Pavione, 4
25050 Paderno F.C. (BS)
ITALY

Tel. +39 0306857073

Email info@palazzani.it

www.palazzani.it



17 m ↑
7,8 m →
200 Kg 👤 👤

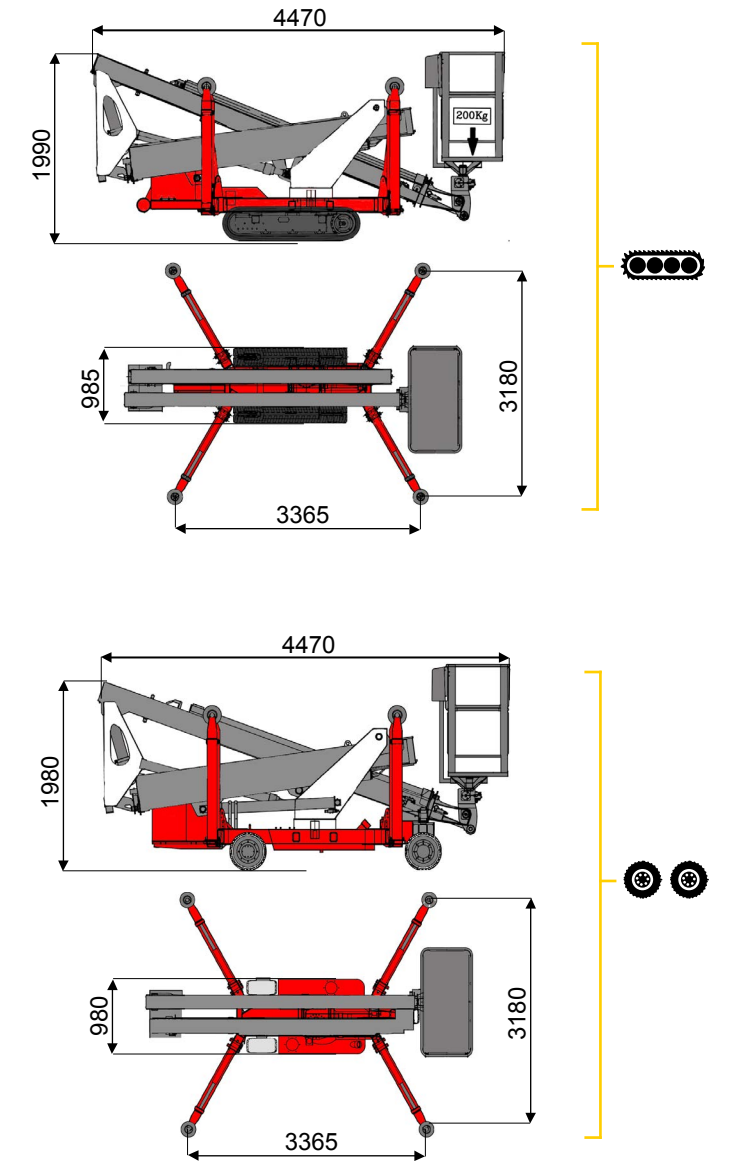
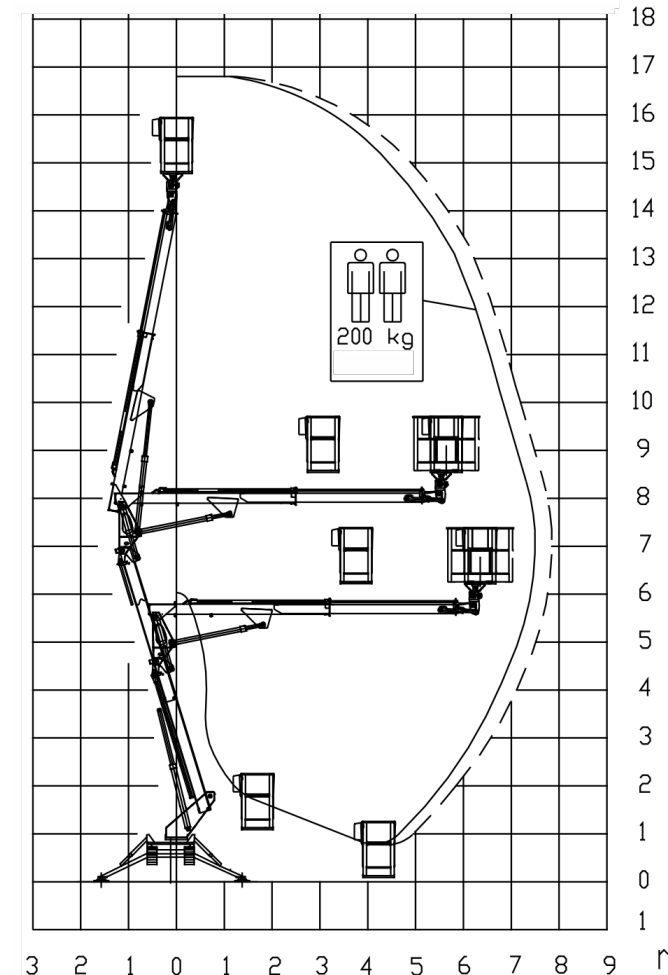

BI-ENERGY Diesel+AC															
TZX 170/C		17 m	7,8 m	200 kg	360°	140x70 cm	90°+90°	3,18 m	18%	31%	2 km/h	2000 kg	13 kN	1,87 kN/m ²	3,2 kN/m ²
TZX 170/R		17 m	7,8 m	200 kg	360°	140x70 cm	90°+90°	3,18 m	18%	25%	2 km/h	2000 kg	13 kN	1,87 kN/m ²	3,2 kN/m ²

Available version:

BI-ENERGY (DIESEL+AC)
ECO (DC+AC)

Characteristics and technical data are informative only and subjected to change without notice.



COMPANY WITH
QUALITY SYSTEM
CERTIFIED BY DNV GL
= ISO 9001 =

Palazzani Industrie S.p.A.
Via del Pavione, 4 - 25050 - Paderno F.C. (BS) - Italy
Tel. (+39) 0306857073
platforms@palazzani.it
www.palazzani.it